

SPEC SHEET ICE 28RFS

ICE

INTERNATIONAL CONSTRUCTION EQUIPMENT

M28RFS0012 / 0608

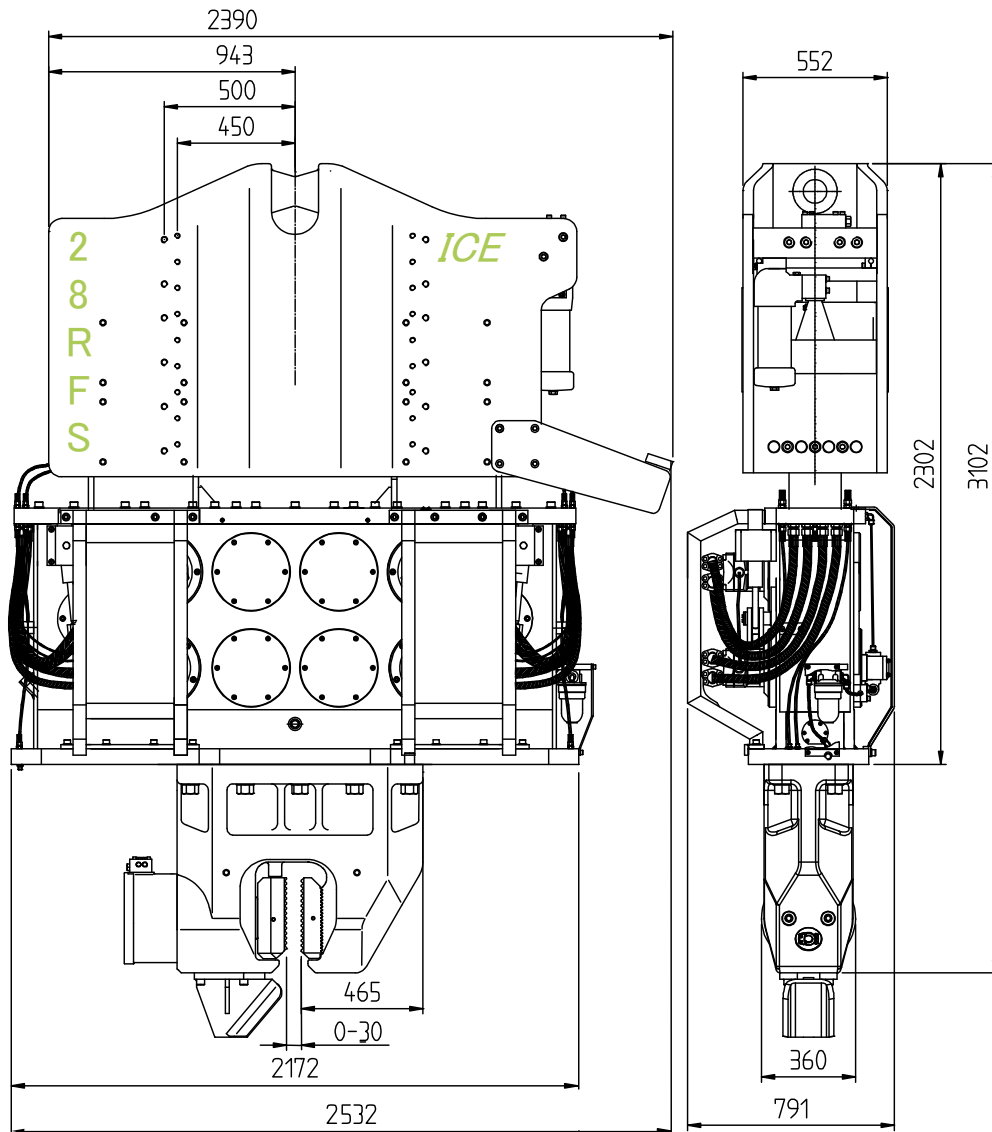

Specifications

Eccentric moment	0-28.0	kgm		
Max. centrifugal force	0-1624	kN		
Max. frequency	2300	rpm		
Max. amplitude excl. 200TU	14.7	mm		
Max. amplitude incl. 200TU	11.0	mm		
Max. static line-pull	400	kN		
Max. hydraulic power	321/436	kW/HP		
Max. operating pressure	350	bar		
Max. oil flow	550	l/min		
Dyn. weight excl. 200TU	3800	kg		
Dyn. weight incl. 200TU	5100	kg		
Total weight incl. 200TU	6500	kg		
Transport weight	7500	kg		
			Clamps:	
			Universal clamp	200TU
			Weight	1300 kg
			Caisson clamps	2 x 200TC
			Weight	4000 kg
			Powerpack:	
			Model	600RF
			Forced lubrication:	
			Max. oil flow	29 l/min